



## Installation Manual

170 liter, 27 Tube Solar Water Heater

Evacuated Tube Integrated (Direct) System, unpressurized



### ***170 liter Solar System Installation Manual:***

This manual explains how to install a system of 27 all glass heat pipe evacuated tubes integrated with a 170 liter storage tank, also referred to as a direct system. The tank is unpressurized, with draining of hot water either by gravity alone, or a downstream pressure pump.



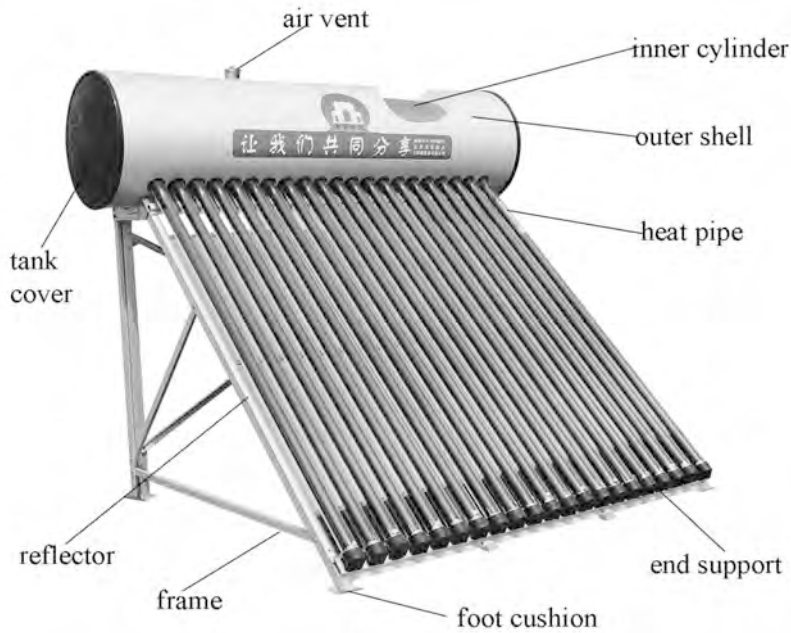
## Table of Contents

170 liter Solar System Installation Manual:.....	1
General System Layout:.....	3
How it works:.....	3
Unpressurized Solar Water Heater Systems:.....	4
Installation Procedure:.....	4
Before Assembling Collectors:.....	4
Unpressurized Tank System Plumbing:.....	5
Manual Control, one pipe.....	6
Manual Control, one pipe, mixing valve:.....	7
Manual Control, Two Pipes, Mixing Valve:.....	8
Automatic Control, Two Pipes, Mixing Valve:.....	9
Controller with backup heater:.....	10
High Pressure Hot Water.....	10
Pipe Size, Multiple Units:.....	11
Frame Attachment to Roof.....	11
Complete Solar Water Heater Assembly.....	12
Assembly Diagram:.....	13
Base Assembly:.....	13
Frame Assembly:.....	14
Storage tank assembly:.....	14
All-Glass Heat Pipes:.....	16
Inspection Checklist:.....	20
Cautions:.....	21

## Illustration Index

Figure 1: General layout of integrated (direct) solar system.....	3
Figure 2: Glass heat pipe inserted into solar water tank.....	3
Figure 3: Unpressurized integrated system cutaway schematic.....	5
Figure 4: 170 l plumbing, one pipe inlet/outlet, raised vent line.....	5
Figure 5: 170 l system plumbing, one pipe, inlet and outlet same.....	6
Figure 6: 170 l plumbing, one pipe inlet/outlet, mixing valve.....	7
Figure 7: 170 l plumbing, fill, drain and mixing valves, inlet and outlet pipes.....	8
Figure 8: 170 l plumbing, two pipes, auto filler, mixing valve.....	9
Figure 9: Multiple integrated solar systems on roof of apartment building.....	11
Figure 10: Straps to hold collector on roof.....	12
Figure 11: Box of evacuated solar tubes.....	12
Figure 12: Reflector (optional) and frame assembly.....	13
Figure 13: Level base for solar heater frame.....	14
Figure 14: Lifting the tank into position.....	14
Figure 15: Tank and frame assembly.....	15
Figure 16: Tube inserted in tank.....	16
Figure 17: All glass heat pipe condenser end.....	16
Figure 18: Insertion of glass heat pipes into tank.....	18
Figure 19: Complete solar heater covered to avoid overheat.....	18

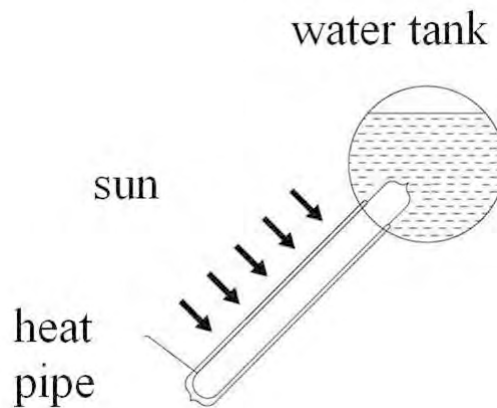
## General System Layout:



**Figure 1: General layout of integrated (direct) solar system**

Notes: the air vent comes from a standpipe inside the tank and in later models exits from tank bottom to keep heat in. Not all models use reflectors.

## How it works:



**Figure 2: Glass heat pipe inserted into solar water tank.**

There are two tricks to the high efficiency of this solar heater. First, a vacuum prevents any conductive or convective heat loss to the environment from the absorber. Second, heat pipes ensure one-way heat transfer from the absorber to the water: the water can not heat the absorber. The selective coating in the inner cover of the evacuated tubes ensures high energy absorption and low heat radiance losses. The liquid in the inner glass heat pipes changes into vapor which then rises up the heat pipe. When heat is exchanged between the

condenser end of the heat pipe and the cold water in the tank, it turns into liquid again, and comes down to the base of the heat pipe. cycle continuously repeats as long as the sun shines. Hot water can be obtained by injecting cold water into the bottom of the tank, with the hot water being forced out the top.

The evacuated tubular collector with heat pipes are quasi-tracking in four seasons, which is to say that as the sun tracks across the sky, about the same absorber area is facing the sun all the time, since the absorber surfaces are cylindrical. The collector will be in operation as long as sun shines. The solar water heater can be in service all year round even in cold climate areas since heat pipes transfer heat in one direction only within the collector and the vacuum prevents convective heat losses.

### **Unpressurized Solar Water Heater Systems:**

All glass heat pipe systems have unpressurized tanks, which means either the collector must be on the roof to allow water to drain from the tank by gravity, or a pressure pump is required downstream from the tank.

Glass heat pipe, unpressurized (gravity) system advantages:

- Lowest cost per liter of water heated
- Glass heat pipes do not corrode
- Can stand freezing temperatures-no water in tube
- Absolute pipe freeze protection if manual control
- No water leaks if bottom of tube broken
- Absolute simplicity

### ***Installation Procedure:***

#### **Before Assembling Collectors:**

Prior to installation of the solar collectors, the following items should be addressed:

- ✓ Decide on location of solar hot water system
- ✓ Check access for piping from solar tank to point of use (bathroom tank?)
- ✓ Install pipe runs from solar tank to point of use
- ✓ Pipes should be installed rising slightly to avoid the creation of air pockets
- ✓ Insulate all pipe runs
- ✓ Ensure all valves are open

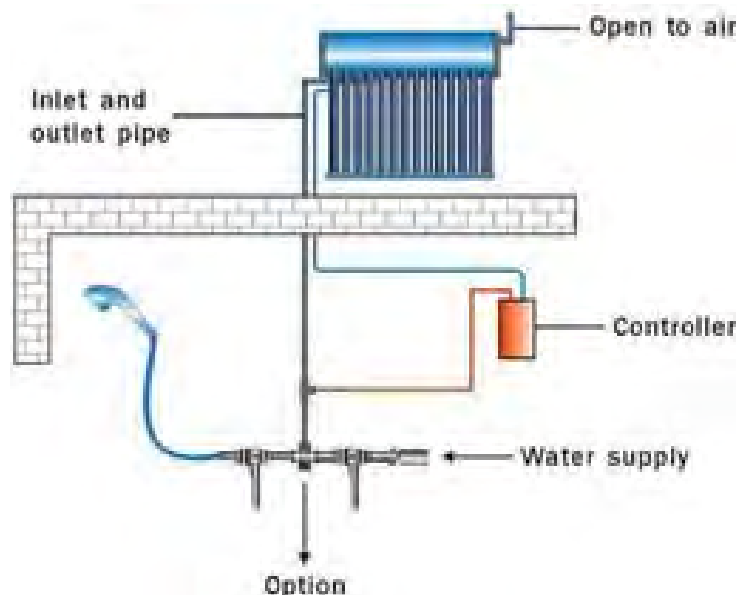
For a general overview of contractor tasks to prepare the site and install a solar water heater, see [http://www.seabirdsolar.com/downloads/solar\\_installation\\_tasks.pdf](http://www.seabirdsolar.com/downloads/solar_installation_tasks.pdf)

### Unpressurized Tank System Plumbing:



**Figure 3: Unpressurized integrated system cutaway schematic.**

Unpressurized systems simply drain by gravity. For higher water pressure at the point of use, either the system must be higher on the roof, or a pressure pump can be installed downstream of the tank. There are several holes in the bottom of the tank: one water inlet (center), a vent, and an overflow, which could either be for hot water out, or for indicating when the tank is full, or even capped off and not used. Inside the tank are standpipes for the two vents on opposite sides of the tank. The standpipes are necessary so that when water overflows out the vent, the drain is at the bottom of the tank, rather than causing corrosion by spilling over the top.



**Figure 4: 170 l plumbing, one pipe inlet/outlet, raised vent line.**



## Manual Control, one pipe

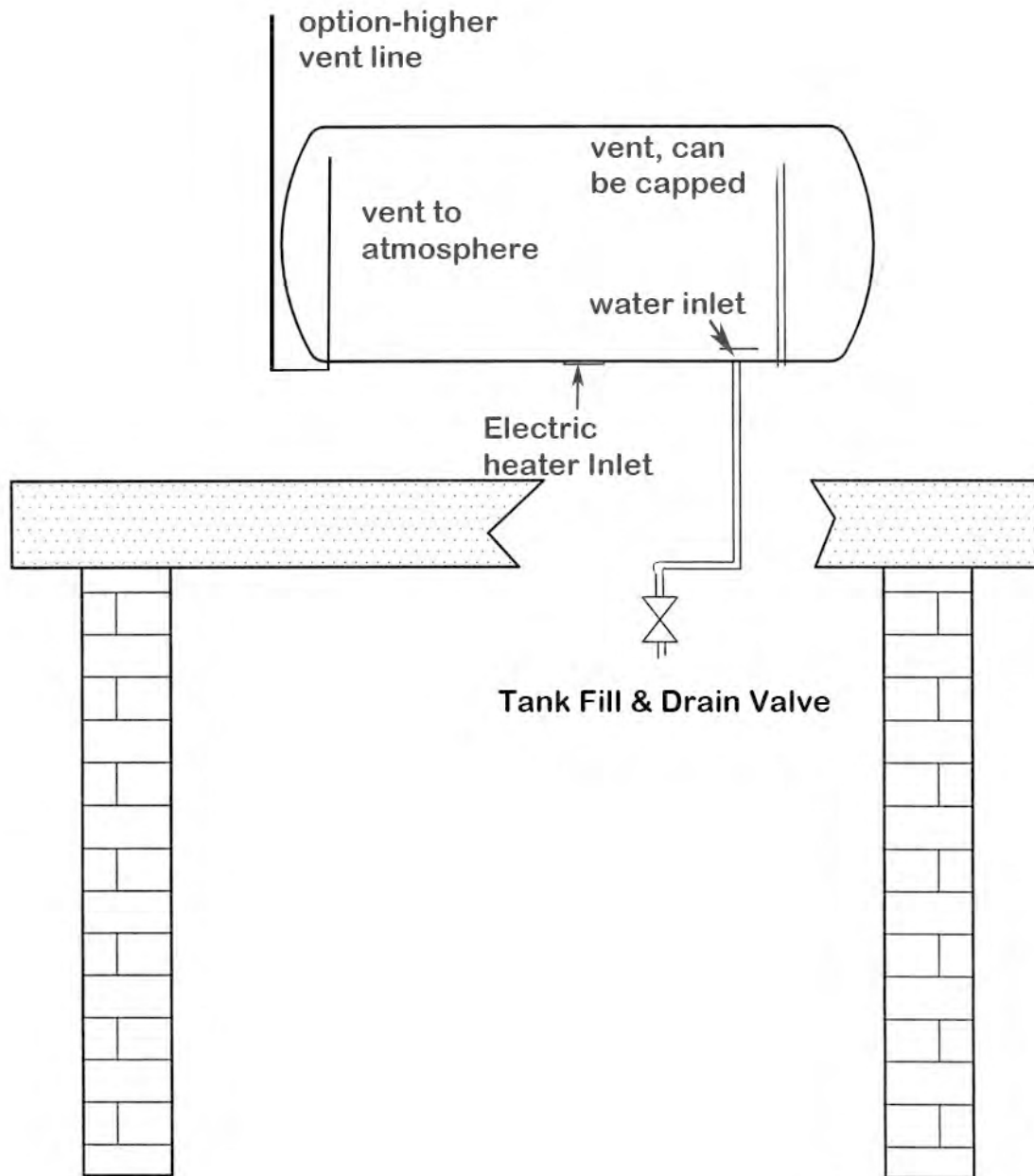
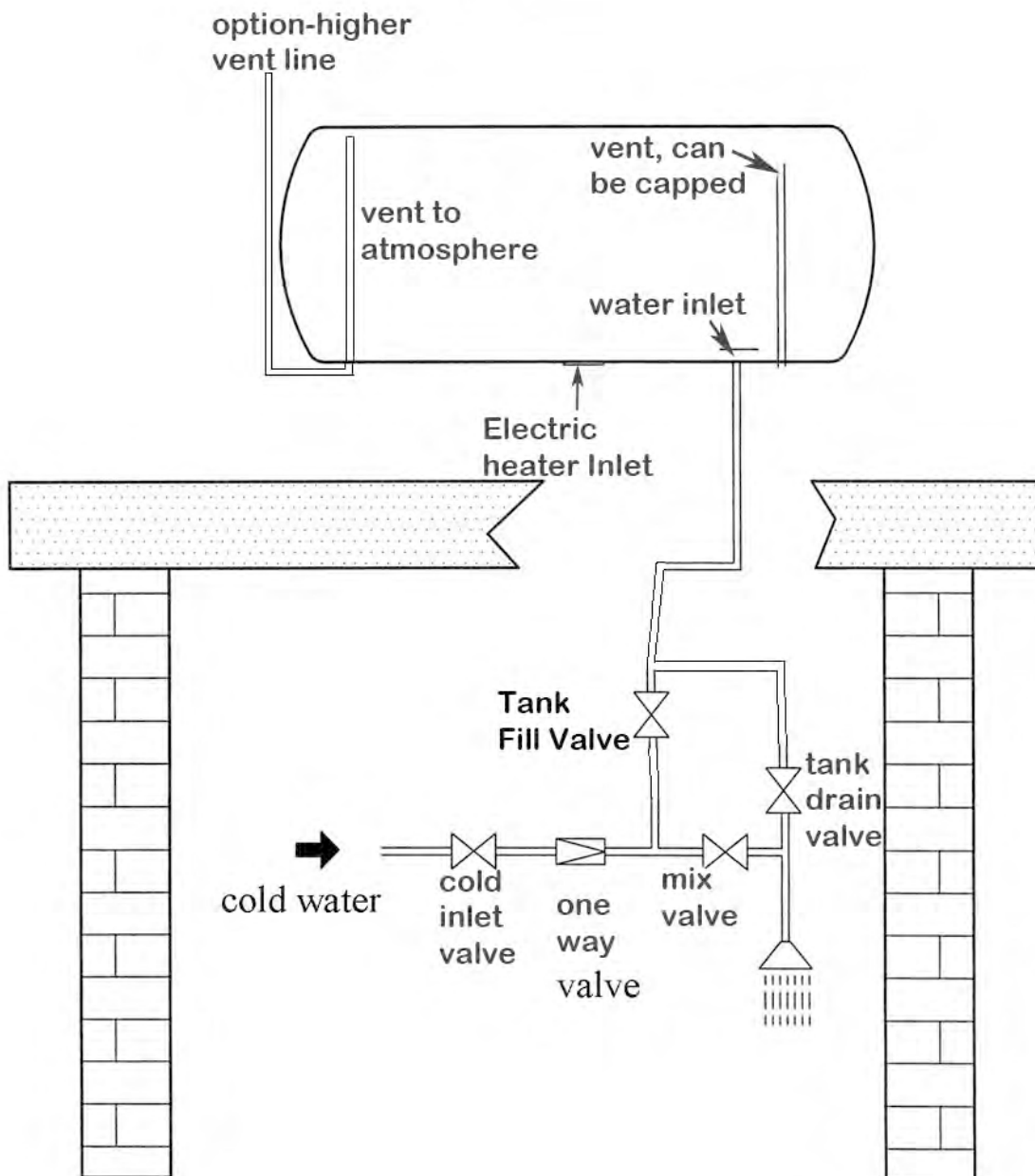


Figure 5: 170 l system plumbing, one pipe, inlet and outlet same

With manual filling and draining, plumbing is most simple: one pipe. The same pipe is used to fill as to drain the tank. The fill and drain valve is manually opened downstairs to fill the tank in the morning. When the tank is full, water comes out the vent, and water is manually shut off. The overflow vent is a standpipe inside the tank that drains at the bottom. One standpipe is longer than the other-this is the air vent. A small tube from the shorter overflow vent can be run downstairs to show when the tank is full. The sun heats the water during the day, then the valve is opened and the same pipe is used to drain the hot water in the late afternoon. One vent can be capped closed to save heat. Overnight, the pipe to the tank can be drained for absolute freeze protection. If not drained, tank insulation is good enough to keep water warm several days.

For a 170 liter gravity drain system, usually the controller is simply to turn on the electric backup heater when all the solar hot water has been used up. A temperature sensor is used to determine when to turn on the electric backup heat. The coldest water is at the bottom of the tank, and is drained first with a one pipe inlet/outlet system.

**Manual Control, one pipe, mixing valve:**



**Figure 6: 170 l plumbing, one pipe inlet/outlet, mixing valve**

Water in the solar tank can reach boiling temperatures, creating a burn hazard for the user. To avoid being burned with overly-hot water, a mixing valve can be added. There

is still only one pipe to the roof, and the tank can still be fully drained, but the cold and hot water can now be mixed to achieve the desired water temperature for use. The cold inlet valve can be left open at all times except for maintenance. The tank fill valve is used to fill the tank in the morning, then closed. In the afternoon, hot water is drained by opening the tank drain valve and using the mixing valve.

### Manual Control, Two Pipes, Mixing Valve:

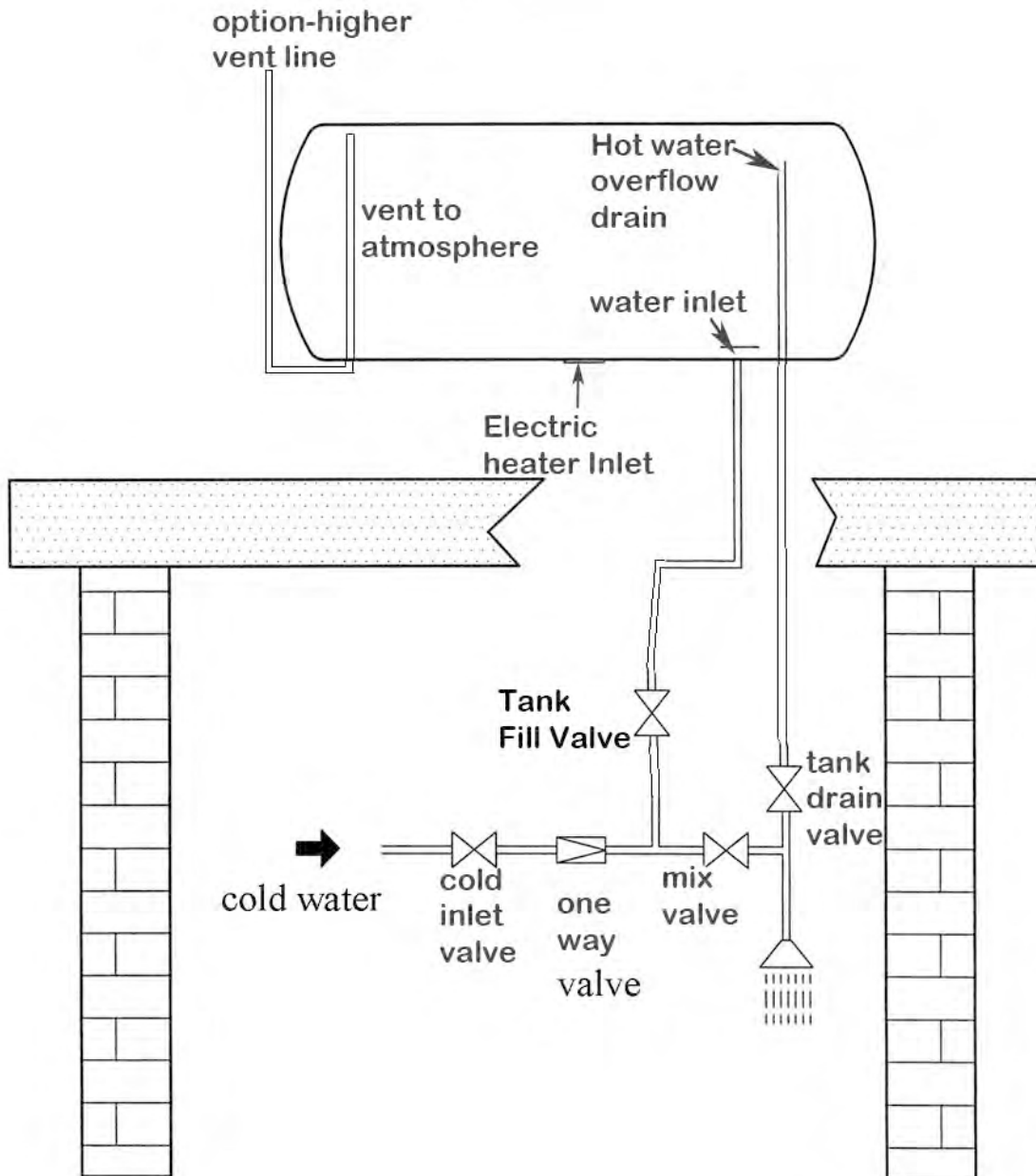


Figure 7: 170 l plumbing, fill, drain and mixing valves, inlet and outlet pipes.

With two pipes, the hot water overflow drain standpipe is used to drain water from the top of the tank. Since hot water rises to the top of the tank, this water is warmer than the water at the bottom of the tank, where the cold water inlet is. A bit of pressure can be added by making the vent line higher than the tank. Now water can be continuously used

from the tank. A pressure pump which turns on when the hot water tap is opened can be used instead of a manual tank drain valve. To keep the tank full of water, the tank fill valve would have to be opened to fill the tank from time to time, using the water pouring out the vent as the signal that the tank is full.

### Automatic Control, Two Pipes, Mixing Valve:

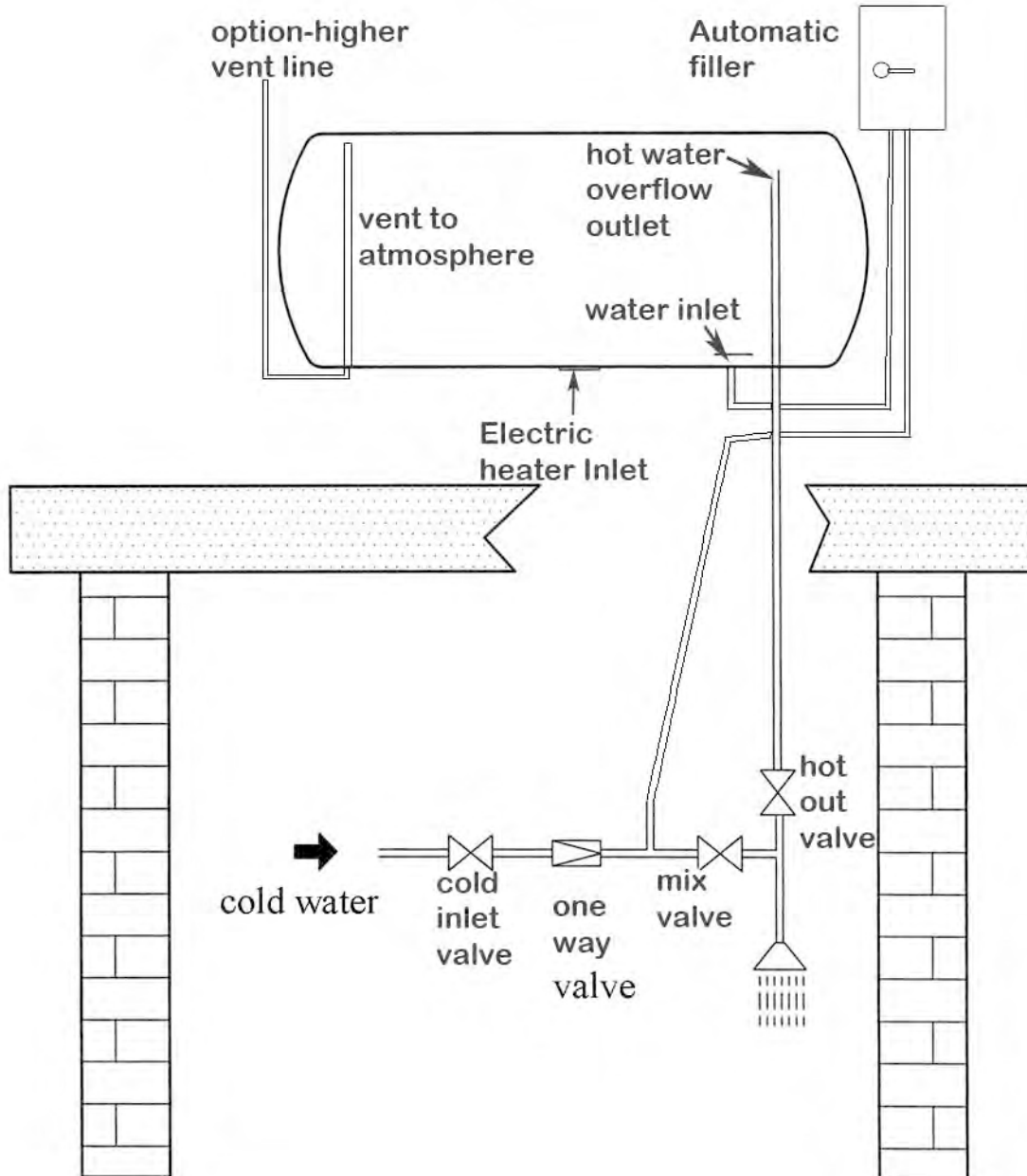


Figure 8: 170 l plumbing, two pipes, auto filler, mixing valve

With an automatic filler mechanism, the tank is kept full of water constantly by connection to a pressurized water supply. The automatic filler functions in a similar way to a toilet bowl filler, which is unpressurized, but through a float mechanism shuts off the pressurized input water when the tank is full. Pressurized supply water is connected directly to the automatic filler. With the automatic filler, the normal pipe is used for filling the tank (at the tank bottom) and the hot water drains out is through overflow standpipe (inside the tank, near the top). The hottest water is on the top of the tank, so

this is where the overflow standpipe is located (inside the tank). The other hole on the bottom of the tank is another standpipe, the air inlet vent, which allows rapid draining without further water input. Look inside the holes on the bottom of the tank to see which is which-the longest pipe is the vent, the shorter pipe is the overflow, or drain, and the hole without a pipe is the filler, or water input to the bottom of the tank, in the center.

### **Controller with backup heater:**

To use the solar water heater as a year-around hot water supply even in cold climates, install the electronic controller and electric heater package. In this case, there is no need for a conventional water heater at all. The electronic controller keeps water at the programmed temperature and can send an alarm if problems are encountered. To ensure the cold water supply to the tank does not freeze, insulate the line heavily, or put the bottom of the tank on the warm side of your roof barrier. This configuration is the simplest way to achieve a constant water temperature.

To add the solar water heater to an existing hot water system, such as electric, oil or gas, connect the cold water supply to the solar heater and connect the outlet from the solar heater to where the cold water would normally enter your existing hot water heater. To preserve the option of removing the solar heater from the system for maintenance, use two T-fittings and two valves, so that cold water can either be routed through the solar heater before going to the conventional heater, or directly to the conventional heater. In this way, the solar tank can be drained and the conventional system continues to operate. Using an in-line, on demand water heater, such as a gas unit is efficient, simple and suitable for off-grid living applications.

### **High Pressure Hot Water**

For high pressure hot water, there are two options: 1. A booster pump downstream from the gravity collector or 2. Raising the level of the gravity system, or adding height to the overflow vent pipe.

To increase the water pressure at the point of use, an in-line pump can be installed downstream of the solar heater, at the hot water outlet valve. To allow the fill line to keep up with the now-faster draining of the tank, cut the overflow, or exit, standpipe down by about one third. In this way, more water can drain out of the tank before being below standpipe level. This gives the filler more time to refill the tank during use. Cut the exit standpipe down too much, though, and you will be draining the bottom, cooler part of the tank first. If input water pressure filling the tank is already high enough to refill the tank in time, cutting down the overflow standpipe may not be required.

A gentler way to add a bit of pressure to the tank is to put the system up higher. If the system itself can not be raised, then raise the level of the automatic filler-this is the same effect, just ensure that the overflow vent is also raised by a similar amount by addition of some pipe to the overflow vent.

For manual control systems, another alternative is to install a J-shaped pipe to the bottom air vent, with the top of the J extending above the tank a meter or two. If using manual control (no auto-filler), simple fill as usual until water pours out the air vent. The pressure is now equal to the situation where the tank is a meter or two higher. This extended vent only works in warm conditions, otherwise the extended vent line freezes.

## Pipe Size, Multiple Units:



**Figure 9: Multiple integrated solar systems on roof of apartment building**

For a solar installation with pipe work of total length 30 to 50 meters, the following dimensions are recommended for pipe work:

Less than 36 tubes	12 mm or $\frac{1}{2}$ inch-possible, but recommend $\frac{3}{4}$ inch.
Up to 90 tubes	22 mm or $\frac{3}{4}$ inch
Up to 120 tubes	128 mm or 1 inch
More than 120 tubes	– use parallel branches of 1 inch each.

Pipe work should be insulated with  $\frac{3}{4}$  inch minimum high temperature pipe insulation, more insulation in more extreme cold environments. Units should not be arranged in series of more than two or three in mid-latitude climates, otherwise the water will be boiling by the last unit. Only if there is continuous use of water should units be connected in long series; otherwise, each unit should supply a point of use, for example, each unit, or series of two units, to supply one apartment.

## Frame Attachment to Roof.

1. Select a suitable location on the roof for the collector. In the northern hemisphere, the collector should face due south, at an angle to the ground equal to the latitude. For example, latitude of 49 degrees would use a collector angle of about 49 degrees.
2. Remove roof tiles at the corners of an area large enough to fit the collector (2).
3. Secure a stainless steel band to a rafter using coach screws and washers (3).
4. Replace the roof tiles, leaving the band protruding (4).
5. Secure the collector frame to the bands.

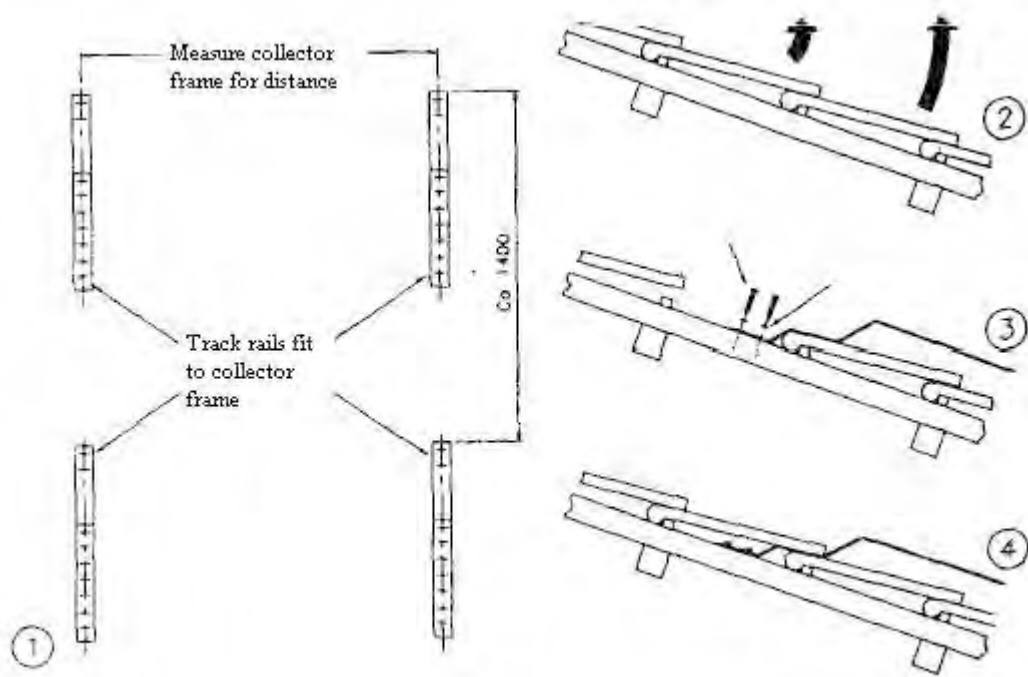


Figure 10: Straps to hold collector on roof.

### **Complete Solar Water Heater Assembly**

All fittings are included in package. Open tube box and check for breakage by observing bottom of tube is silver, not cloudy, which indicates pressure loss. Not all gravity systems have reflectors.



Figure 11: Box of evacuated solar tubes



## Assembly Diagram:

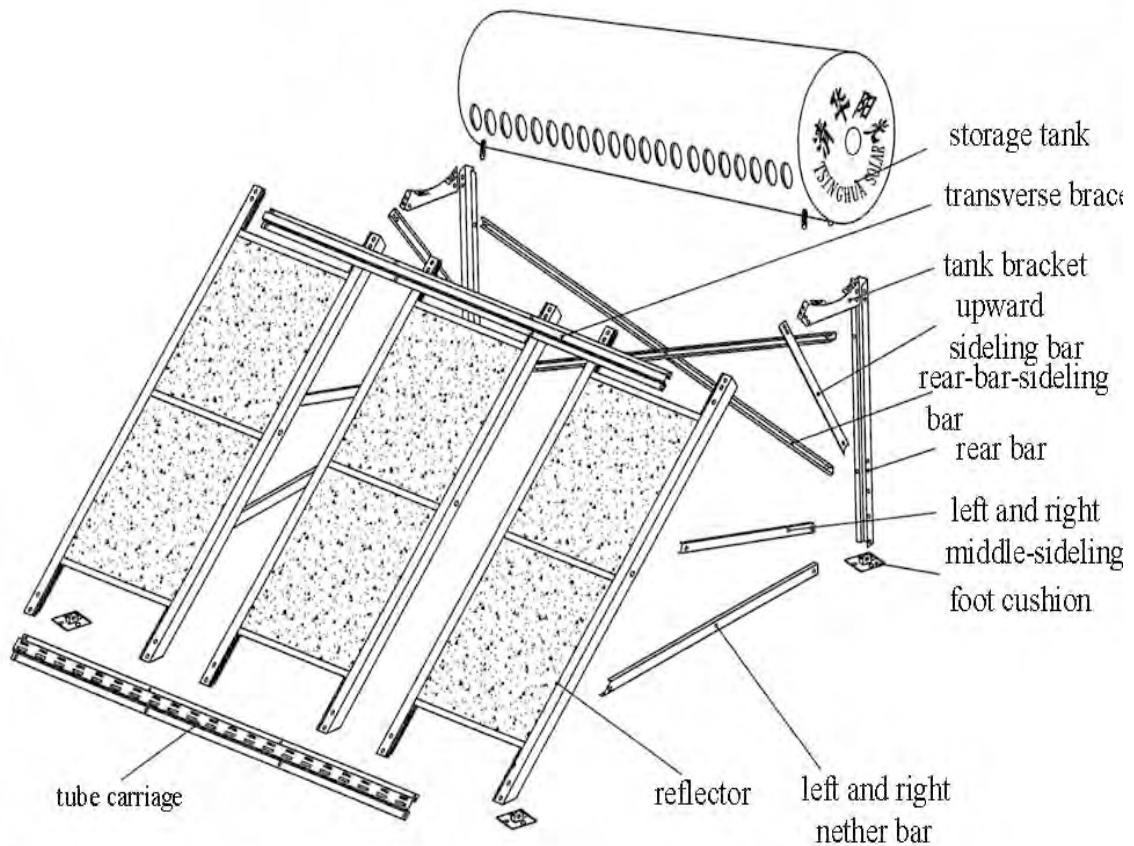


Figure 12: Reflector (optional) and frame assembly

### Base Assembly:

Not all models have reflector; skip this step or make your own reflector if your system does not include a reflector. A clean reflector can increase efficiency, but also can collect snow, twigs, dust and debris, depending on the environment.

1. Place the module-type reflectors in parallel;
2. Overlap the holes in the tube carriage (the larger holes facing outside) with the slots in the triangular joint of reflector bar, and then connect them with bolts.
2. Overlap the slots in the transverse braces (the shorter side of transverse brace facing outside) with the slots in the other end of reflector bar, and then connect them with bolts.
4. Cross-connect the rear brace bars with the rear bars using bolts.
5. Make up a level base for the frame as required; facing due south.



**Figure 13: Level base for solar heater frame.**

### **Frame Assembly:**

1. Push the triangular joint of the stainless steel tank brackets into the gap between transverse braces and horizontal bar, and then attach the braces, brackets and the horizontal bars with bolts; connect the other joint of the brackets with the rear bars.

2. Connect the brace bars and lower braces (tilt angle 45°).

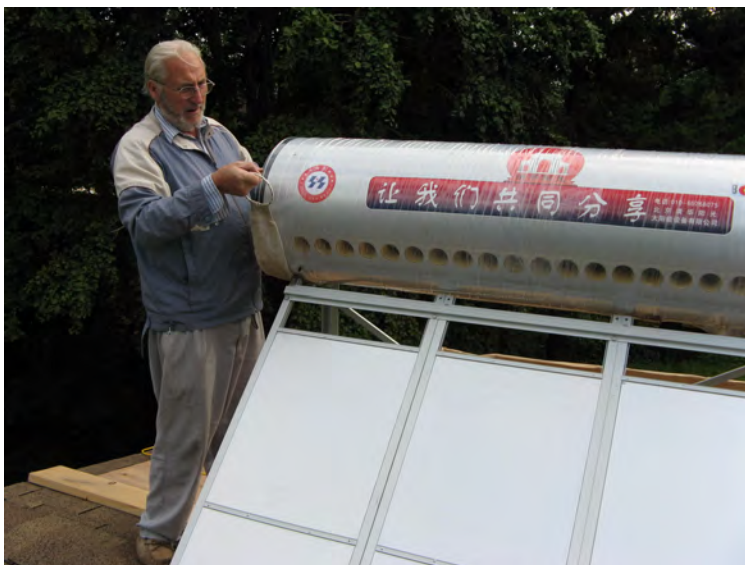
Connect the upward, middle brace bars and lower braces (tilt angle 30°).

3. Fix the foot cushion.

NOTE: Assembly of the unit is not finished; do not fit all the nuts tight until the tubes are installed.

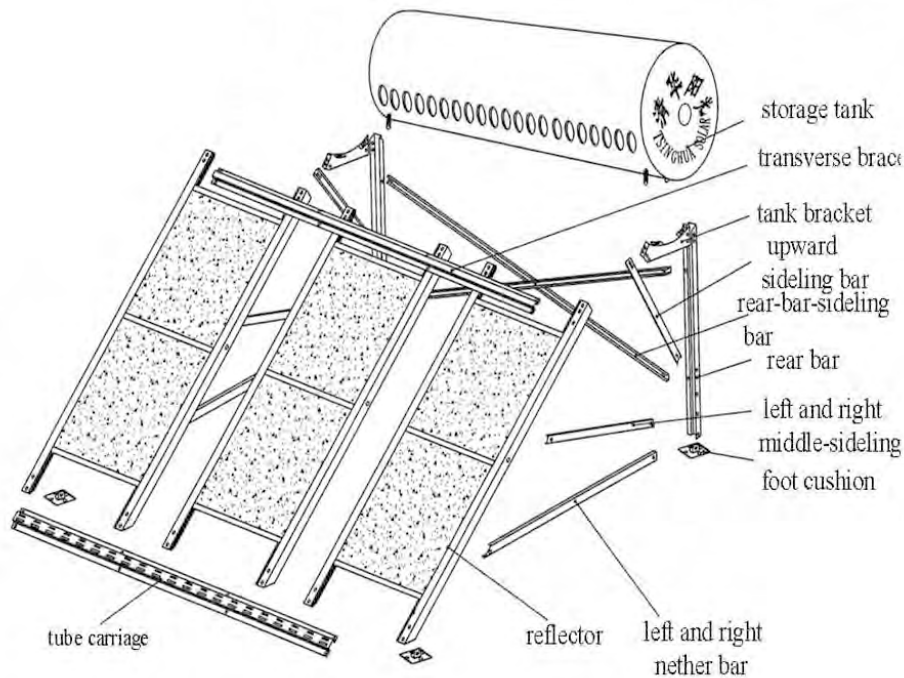
### **Storage tank assembly:**

Lift the storage tank into position on the frame. Two persons make the job easier, and a strap around the tank makes adjusting the position easier.



**Figure 14: Lifting the tank into position**

Rotate the tank and lower on to the frame. Bolts on the cylinder fit into the slots of the frame brackets. Fit nuts finger tight. Make sure the holes for the tubes are facing forward, with the water connections facing down on the bottom.



**Figure 15: Tank and frame assembly**

Push the tube into the locating hole; avoid excessive twisting of the tube to avoid damaging the inner cover of the tube. Do not use any petroleum based lubrication in contact with the silicon seals, as petroleum based lubricants can degrade the seals, leading to leaks. Use vegetable oil or water based lubricants if needed.



**Figure 16: Tube inserted in tank.**

Insert tube bottom into the plastic end cap protector, then fix the protector into the shorter holes in the bottom tube carriage brace, as well as the left/right flexible fasteners into the longer holes.

Slide the black rubber wind- blocking seals up the tube until its outside edge fits well with the cylinder.

Insert one tube on each side of the tank to achieve alignment of the tank and the frame before proceeding with others.

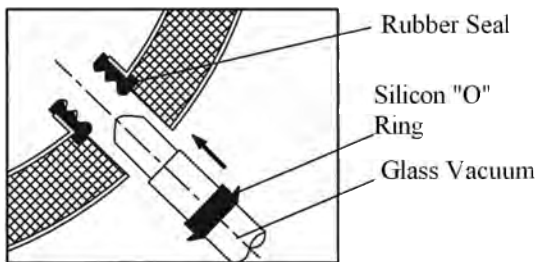
Fix all the frame nuts tight after all the tubes are assembled to the tank.

### **All-Glass Heat Pipes:**

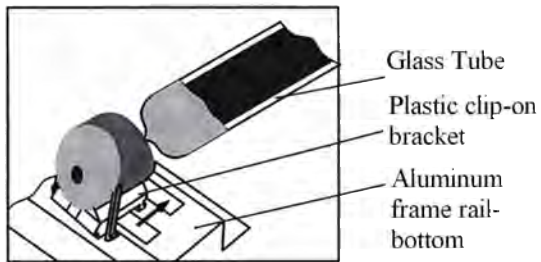


**Figure 17: All glass heat pipe condenser end**

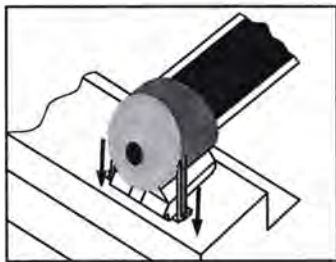
All glass heat pipe tubes come pre-assembled and need only be inserted into the water tank.



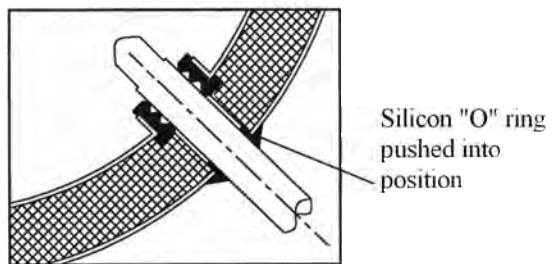
A



B



C



D

**Figure 18: Insertion of glass heat pipes into tank.**

Glass heat pipes with rubber collars are used with unpressurized systems. Glass heat pipes, being pre-assembled, need no preparation other than carefully sliding them into the tank after the tank and frame are assembled. The plastic bottom cap (Picture C, Figure 18) snaps into the bottom rail to hold the tube in place. Rubber O-ring seals keep dust out. Do not use petroleum lubricant on silicon seals inside the tank; this will destroy the seal. If you must lubricate, use a few drops of water based lubricant or light vegetable oil.

Cover the solar tubes to prevent overheating if there is no water in the tank and the tubes are in full sun.



**Figure 19: Complete solar heater covered to avoid overheat.**

Connect the cold water line in and hot water line out to the bottom of the tank. Insulate all water lines. For the unpressurized (gravity) glass heat pipe system, an automatic water filler shutoff valve can be installed on the bottom of the tank. This 10 cm cylinder-shaped valve allows cold water to flow in until the tank is full. When hot water is used, the valve opens again to keep the tank full, much like a float valve keeps the toilet bowl full of water, but unpressurized. Without an automatic shutoff valve, cold water filling the tank must be shut off manually when the tank is full. Water spills out of the overflow vent when the unpressurized tank is full. A tube attached to the overflow vent leading downstairs can be used as a quick indicator of when the tank is full.

If the optional electric backup heater was purchased, install it now on the bottom of the tank, in the purpose-built mount. See the controller manual download for presetting the desired water temperature. For the unpressurized system, greater water pressures are obtained by placing the solar collector higher than the point of water use, with gravity water pressure from a two story roof being higher than from a one-story roof.



**SeabirdSolar**  
Panels & Pumps  
FreeFuel, Forever!

## **Inspection Checklist:**

1. After joining the heat pipes to the tank, check to see if there are any leaks between them. Adjust the connection to ensure there are no leaks.
2. The non-pressurized (gravity) system with glass heat pipes is filled with water, which spills out the overflow vent when the tank is full. Ensure no leaks.
3. A lightning arrester should be considered if you live where thunderstorms are common and the heater is installed at the highest point on your roof.
4. Water piping systems used with solar heating should be of high quality and capable of high temperature operation [100 degrees Celcius]
5. Whatever is supporting the frame (your roof) should be strong enough to avoid damage-remember that water is heavy.
6. All exposed piping should be insulated properly to prevent heat loss and provide freezing protection. In the areas with ambient temperature under -5 Celsius, pipes need freeze protection. The solar water heater will not freeze, but the pipes connected to it also need freeze protection, best accomplished by heavy insulation and keeping the pipes inside the warm envelope of the building for as long as possible. Avoid long outside pipe runs in freezing climates.

## **Cautions:**

1. Gloves and eye protection must be used when handling glass tubes
2. avoid scratching or any sudden shock to tubes
3. unpack and install tubes after all pipe work has been completed
4. Leaving tubes exposed to full sun for long periods without water in the tank will eventually degrade performance.
5. Do not use any petroleum based lubricants in contact with silicon seals, as petroleum can degrade silicon; use vegetable or water based lubricants.